

Kinetix 2000 Slot-filler Module

This section contains dimensions and catalog numbers for the 2093-PRF slot-filler module.

IMPORTANT

The Kinetix 2000 slot-filler module (catalog number 2093-PRF) is compatible with all Kinetix 2000 systems. Power rail slots not occupied by an IAM, AM, or shunt module, must have a slot-filler module installed.

Slot-filler Module Dimensions

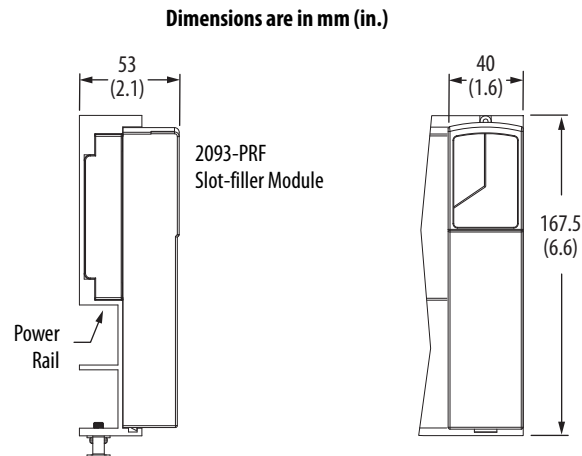

Kinetix 7000 High Power Servo Drives



The Kinetix 7000 high-power servo drive is designed to accommodate the most demanding requirements and extends the benefits of Kinetix Integrated Motion to applications up to 149 kW. The Kinetix 7000 high power drive supports three-phase AC input power (380...480V AC) and DC input for common bus applications. In addition, the safe-off capability integrated into this drive increases productivity by allowing manufacturers and machine builders to implement machine solutions that provide both safety and maximum machine availability.

The Kinetix 7000 servo drives provide Integrated Motion capability through the sercos interface and are part of the Kinetix Integrated Motion solution.

Kinetix 7000 Servo Drive Features and Indicators

Kinetix 7000 Drive Features and Indicators

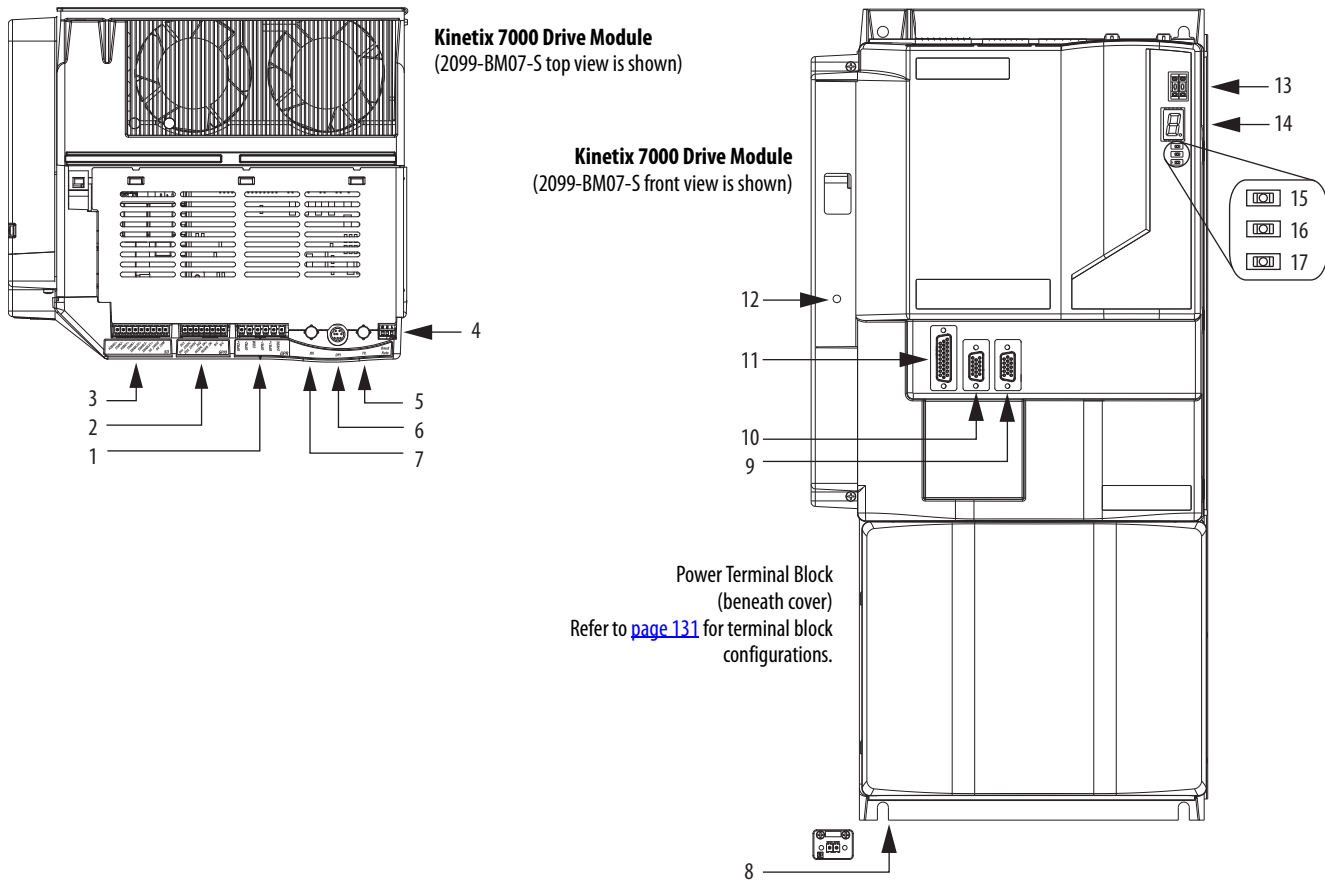

Item	Description
1	General purpose (GPR) connector
2	General purpose (GPIO) connector
3	Safe-off (SO) connector
4	Sercos communication rate and optical power switches
5	Sercos transmit (Tx) connector
6	DPI connector

Item	Description
7	Sercos receive (Rx) connector
8	Control power (CP) connector (facing down)
9	Auxiliary feedback (AF) connector
10	Motor feedback (MF) connector
11	I/O (IOD) connector
12	Control power status indicator

Item	Description
13	Sercos node address switches
14	Seven-segment fault status indicator
15	Drive status indicator
16	COMM status indicator
17	Bus status indicator

Kinetix 7000 Power Terminal Blocks

Kinetix 7000 Drive Module, front view
(2099-BM07-S is shown)

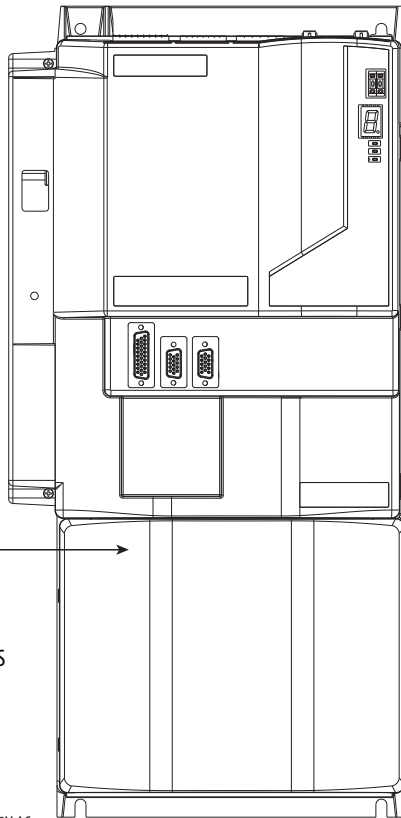

Power Terminal Block
(beneath cover)

Power Terminal Block
2099-BM11-S and 2099-BM12-S

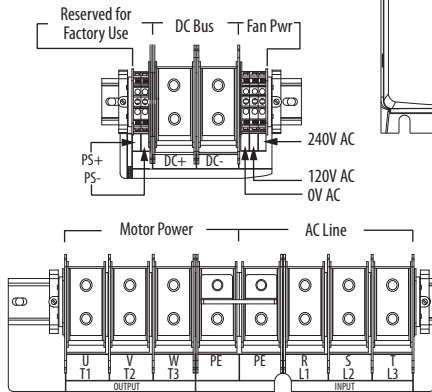

Power Terminal Block
2099-BM06-S, 2099-BM07-S, and 2099-BM08-S

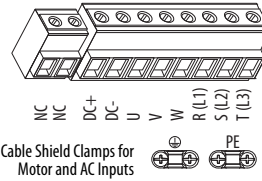

Power Terminal Block
2099-BM09-S

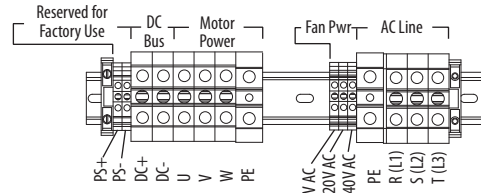

Power Terminal Block
2099-BM10-S

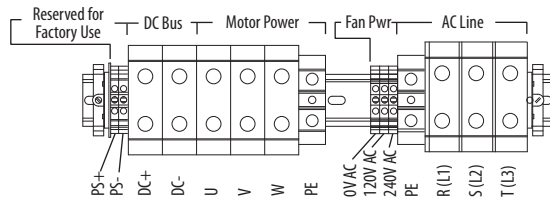

Kinetix 7000 System Power Component Compatibility Charts

These tables provide input power component combinations for Kinetix 7000 drives with compatible motors. Combinations are designed to provide optimum performance in common-bus configurations.

Input Power Components with HPK-B (460V) Motors

Kinetix 7000 Drive Cat. No.	Common Bus Accessories		Compatible Motors
	8720MC Regenerative Power Supply ⁽¹⁾ 8720MC-RPS	8720MC Line Reactor ⁽¹⁾	
2099-BM07-S	8720MC-RPS065BM	8720MC-LR05-048B	HPK-B1307C
2099-BM08-S			HPK-B1308C
			HPK-B1307E
			HPK-B1310C
2099-BM09-S	8720MC-RPS065BM and 8720MC-RPS065BS	8720MC-LR10-062B	HPK-B1308E
		8720MC-LR05-048B (two units)	HPK-B1609E HPK-B1613C
2099-BM11-S		8720MC-LR10-062B (two units)	HPK-B1611E HPK-B1815C
		8720MC-RPS190BM	8720MC-LR10-100B (two units)
HPK-B2010C			
HPK-B2010E			
HPK-B2212C			
2099-BM12-S			HPK-B2010E HPK-B2212C HPK-B2510C

(1) Regenerative Power Supply (RPS) selection is for this single motor/drive combination. When combining multiple drives on the same RPS module, the selection can change.

Input Power Components with HPK-E (400V) Motors

Kinetix 7000 Drive Cat. No.	Common Bus Accessories		Compatible Motors
	8720MC Regenerative Power Supply ⁽¹⁾	8720MC Line Reactor ⁽¹⁾ 8720MC-LRxx-xxxB	
2099-BM08-S	8720MC-RPS065BM	8720MC-LR05-048B	HPK-E1307C
2099-BM09-S		8720MC-LR14-070B	HPK-E1308E
		8720MC-LR10-062B	HPK-E1310C
2099-BM11-S	8720MC-RPS065BM and 8720MC-RPS065BS	8720MC-LR05-048B (two units)	HPK-E1613C
		8720MC-LR10-062B (two units)	HPK-E1609E HPK-E1611E HPK-E1815C
	8720MC-RPS190BM	8720MC-LR10-100B (two units)	HPK-E1613E HPK-E2010C

(1) Regenerative Power Supply (RPS) selection is for this single motor/drive combination. When combining multiple drives on the same RPS module, the selection can change.

Input Power Components with MPL-B (460V) Motors

Kinetix 7000 Drive Cat. No.	Common Bus Accessories		Compatible Motors
	8720MC Regenerative Power Supply ⁽¹⁾	8720MC Line Reactor ⁽¹⁾	
2099-BM06-S	8720MC-RPS065BM	8720MC-LR05-048B	MPL-B540K
			MPL-B560F
			MPL-B580F
			MPL-B580J
			MPL-B640F
			MPL-B660F
			MPL-B680D
			MPL-B680F
			MPL-B860D
			MPL-B960B
		MPL-B980B	
2099-BM07-S			MPL-B880C
2099-BM08-S			MPL-B880D
	8720MC-LR10-062B	MPL-B960C	
		MPL-B960D	
		MPL-B980C	
		MPL-B980D	

(1) Regenerative Power Supply (RPS) selection is for this single motor/drive combination. When combining multiple drives on the same RPS module, the selection can change.

Input Power Components with MPM-B (480V) Motors

Kinetix 7000 Drive Cat. No.	Common Bus Accessories		Compatible Motors
	8720MC Regenerative Power Supply ⁽¹⁾	8720MC Line Reactor ⁽¹⁾	
2099-BM06-S	8720MC-RPS065BM	8720MC-LR05-048B	MPM-B1651M
2099-BM06-S			MPM-B1652E
2099-BM06-S			MPM-B1652F
2099-BM06-S			MPM-B1653C
2099-BM06-S			MPM-B1653E
2099-BM06-S			MPM-B1653F
2099-BM06-S			MPM-B2152C
2099-BM07-S			MPM-B2152F
2099-BM06-S			MPM-B2152M
2099-BM06-S			MPM-B2153B
2099-BM07-S			MPM-B2153E
2099-BM07-S			MPM-B2153F
2099-BM07-S			MPM-B2154B
2099-BM07-S			MPM-B2154E
2099-BM06-S			MPM-B2154F

(1) Regenerative Power Supply (RPS) selection is for this single motor/drive combination. When combining multiple drives on the same RPS module, the selection can change.

Input Power Components with RDB-B (480V) Motors

Kinetix 7000 Drive Cat. No.	Common Bus Accessories		Compatible Motors
	8720MC Regenerative Power Supply ⁽¹⁾	8720MC Line Reactor ⁽¹⁾	
2099-BM06-S	8720MC-RPS065BM	8720MC-LR05-048B	RDB-B2152C
2099-BM06-S			RDB-B2153C
2099-BM07-S			RDB-B29029
2099-BM06-S			RDB-B29036
2099-BM08-S			RDB-B29039
2099-BM06-S			RDB-B41016
2099-BM08-S			RDB-B41018
2099-BM06-S			RDB-B41024
2099-BM09-S			RDB-B41026
2099-BM09-S			RDB-B41035

(1) Regenerative Power Supply (RPS) selection is for this single motor/drive combination. When combining multiple drives on the same RPS module, the selection can change.

Technical Specifications - Kinetix 7000 High Power Servo Drives

Kinetix 7000 Drive Power Specifications

Attribute	2099-BM06-S	2099-BM07-S	2099-BM08-S	2099-BM09-S	2099-BM10-S	2099-BM11-S	2099-BM12-S
AC input voltage	342...528V AC rms three-phase (380...480V nom)						
AC input frequency	47...63 Hz						
Bandwidth ⁽¹⁾ Velocity loop Current loop	500 Hz 1300 Hz						500 Hz 500 Hz
PWM frequency	4 kHz						2 kHz
Main AC input current Nom (rms) Max inrush (A peak)	36.7 A 18.0 A	47.7 A 18.0 A	59.6 A 18.0 A	90.1 A 96.0 A	117 A 118 A	169 A 141 A	233 A 141 A
DC input voltage	450...750V DC						
DC input current	42.9 A	55.7 A	69.7 A	105 A	137 A	204 A	281 A
Control power input Voltage	18...30V DC (24V DC, nom)						
Control power DC input current Nom (rms) Maximum inrush (rms)	3.3 A 6.0 A						
Continuous output current (rms)	40.0 A	52.0 A	65.0 A	96.0 A	125 A	180 A	248 A
Continuous output current (0-pk)	56.0 A	73.0 A	92.0 A	135 A	176 A	254 A	351 A
Peak output current (rms) 3 s duration 60 s duration	68.0 A 51.0 A	80.0 A 60.0 A	104 A 78.0A	154 A 115 A	163 A 138 A	312 A 234 A	372 A 273 A
Peak output current (0-pk) 3 s duration 60 s duration	96.0 A 72.0 A	113 A 84.8 A	147 A 110 A	217.7 A 162.6 A	230.5 A 195 A	441 A 331 A	526 A 386 A
Bus overvoltage	800V DC						
Bus undervoltage	275...560V DC ⁽³⁾						
Continuous power output, nom	22 kW	30 kW	37 kW	56 kW	75 kW	112 kW	149 kW
Continuous power output (Hp)	30 Hp	40 Hp	50 Hp	75 Hp	100 Hp	150 Hp	200 Hp
Maximum power cycles/minute AC line DC bus	4 per minute (pre-charge provided by drive) 2 per minute (DC pre-charge provided by the regenerative power supply)						
DC bus discharge time	3 minutes after removal of main AC power						
Efficiency	97.5%						
Total capacitance ⁽²⁾	1800 µF	2400 µF	3000 µF	4500 µF	6000 µF	8400 µF	8400 µF
Short-circuit current rating	200,000 A (rms) symmetrical						

(1) Bandwidth values vary based on tuning parameters and mechanical components.

(2) If DC input is supplied to 2099-BM09-S, 2099-BM10-S, or 2099-BM11-S drives, the precharge capability must be provided at the system level. Disconnect switches must not be used between the input of the drive and a common DC bus without the use of an external precharge device.

(3) Bus undervoltage can vary based on input line voltage.

Circuit Breaker/Fuse Specifications

While circuit breakers offer some convenience, there are limitations for their use. Circuit breakers do not handle high current inrush as well as fuses. Make sure the selected components are properly coordinated and meet acceptable codes including any requirements for branch circuit protection. Evaluation of the short-circuit available current is critical and must be kept below the short-circuit current rating of the circuit breaker.

Use class CC, T, RK1, or J fuses, with current rating as indicated in the table below. The following fuse examples and short-circuit current ratings are recommended for use with the 2099-BMxx-S drives when the Line Interface Module (LIM) is not used.

IMPORTANT LIM modules (catalog numbers 2094-BLxxS and 2094-XL75S-Cx) provide branch circuit protection to the Kinetix 7000 drive. Follow all applicable NEC and local codes.

Fuse Specifications (AC input)

Drive Cat. No.	Bussmann Fuse	Dual Element Time Delay Fuse (min/max) A rms	Non-Time Delay Fuse (min/max) A rms	Motor Circuit Protector (max) A rms
2099-BM06-S	LPJ-90SP	50/90	50/150	50
2099-BM07-S	LPJ-110SP	60/110	60/200	70
2099-BM08-S	LPJ-125SP	80/125	80/250	100
2099-BM09-S	LPJ-200SP	125/200	125/300	125
2099-BM10-S	LPJ-250SP	150/250	150/500	150
2099-BM11-S	LPJ-400SP	225/400	225/600	250
2099-BM12-S	LPJ-500SP	300/550	300/700	400

Fuse Specifications (DC common bus)

Drive Cat. No.	Bussmann Fuse	Mersen Fuse ⁽¹⁾
2099-BM06-S	FWJ-80A	HSJ80
2099-BM07-S	FWJ-100A	HSJ90
2099-BM08-S	FWJ-125A	HSJ100
2099-BM09-S	FWJ-175A	HSJ175
2099-BM10-S	FWJ-200A	HSJ200
2099-BM11-S	FWJ-500A	HSJ400
2099-BM12-S	FWJ-500A	HSJ400

(1) Mersen fuses were formerly known as Ferraz Shawmut.

Weight Specifications

Drive Cat. No.	Weight, approx kg (lb)
2099-BM06-S	18.55 (40.9)
2099-BM07-S	
2099-BM08-S	

Drive Cat. No.	Weight, approx kg (lb)
2099-BM09-S	37.2 (82.0)
2099-BM10-S	
2099-BM11-S	71.4 (157.5)
2099-BM12-S	

Contactor Ratings

The table below lists the recommended contactor ratings for Kinetix 7000 drives installed without a Line Interface Module.

Drive Cat. No.	Contactor	Safety Contactor	Coil Type	Coil Voltage Requirements
2099-BM06-S	100-C43DJ01	100S-C43-DJD4C	Standard with Diode	24V DC
2099-BM07-S	100-D95EN11	100S-D95EN22C	Electronic Coil ⁽¹⁾	24V DC for control and 480V AC for coil power
2099-BM08-S				
2099-BM09-S				
2099-BM10-S	100-D140EN11	100S-D140EN22C		
2099-BM11-S	100-D180EN11	100S-D180EN22C		
2099-BM12-S	100-D250EN11	100S-D250EN22C		

(1) Electronic coil control power requirements = 24V DC @ 15 mA.

Power Dissipation Specifications

Use this table to size an enclosure and calculate required ventilation for your Kinetix 7000 drive system.

Drive Cat. No.	Usage as % of Rated Power Output	
	W	
	50%	100%
2099-BM06-S	294	465
2099-BM07-S	388	619
2099-BM08-S	452	730

Drive Cat. No.	Usage as % of Rated Power Output	
	W	
	50%	100%
2099-BM09-S	645	1072
2099-BM10-S	882	1479
2099-BM11-S	1275	2125
2099-BM12-S	1438	2437

Maximum Feedback Cable Lengths

Although motor power and feedback cables are available in standard lengths up to 90 m (295.3 ft), the drive/motor/feedback combination can limit the maximum feedback cable length. This table assumes the use of recommended cables as shown in the Kinetix Motion Accessories Technical Data, publication [KNX-TD004](#).

Cable Lengths for Compatible Rotary Motors

Motor Cat. No.	Absolute High-resolution (5V) Encoder m (ft)	Absolute High-resolution (9V) Encoder m (ft)
MPL-B5xxx... MPL-B9xxx-S/M		90 (295.3)
MPM-B165xx... MPM-B215xx-S/M		90 (295.3)
RDB-B215xx-7/3	30 (98.4)	
RDB-B290xx-7/3 or RDB-B410xx-7/3	90 (295.3)	
HPK-Bxxxx-S/M or HPK-Exxxx-S/M		90 (295.3)

Dimensions - Kinetix 7000 High Power Servo Drives

2099-BM06-S, 2099-BM07-S, and 2099-BM08-S Dimensions

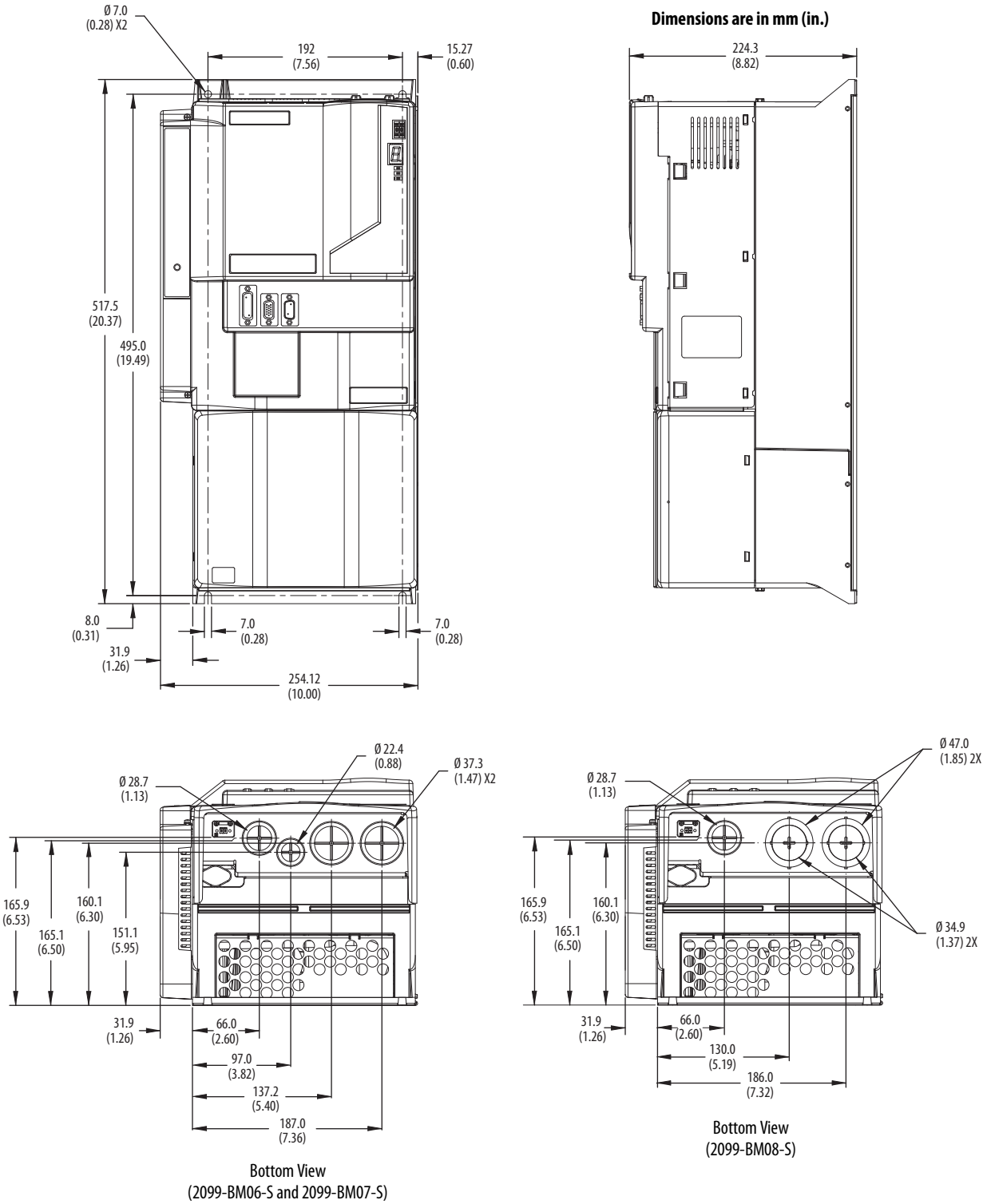

2099-BM09-S and 2099-BM10-S Dimensions

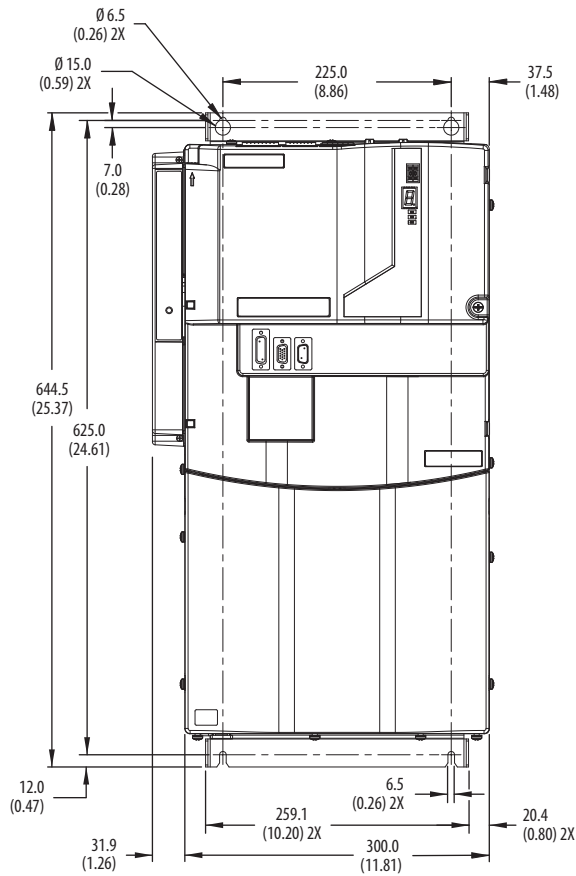

Dimensions are in mm (in.)

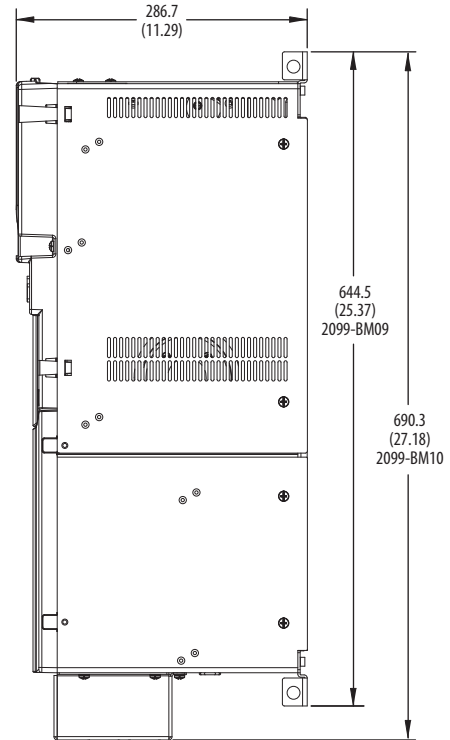

Some Components are Removed for Clarity

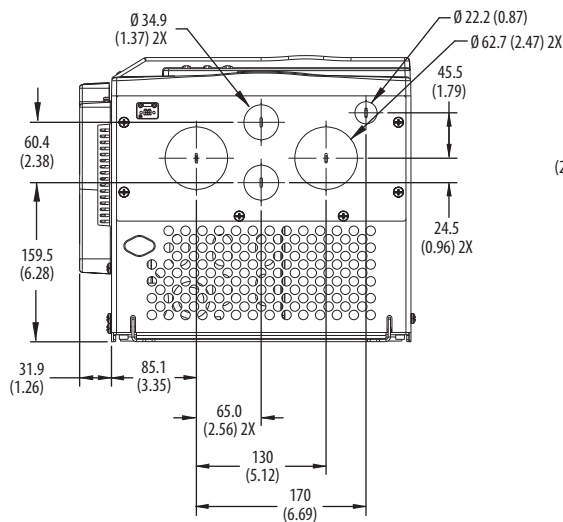

Bottom View
(2099-BM09-S)

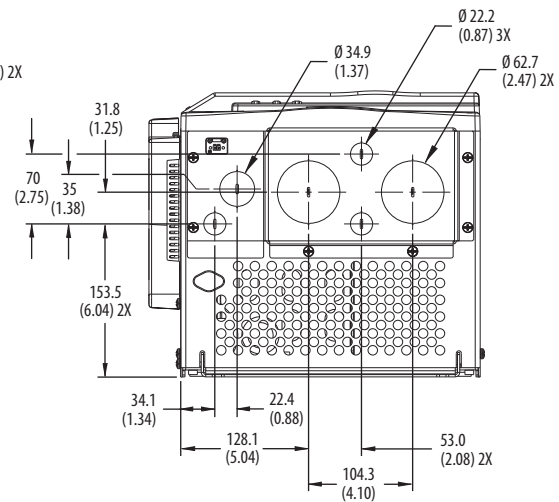

Bottom View
(2099-BM10-S)

2099-BM11-S and 2099-BM12-S Dimensions

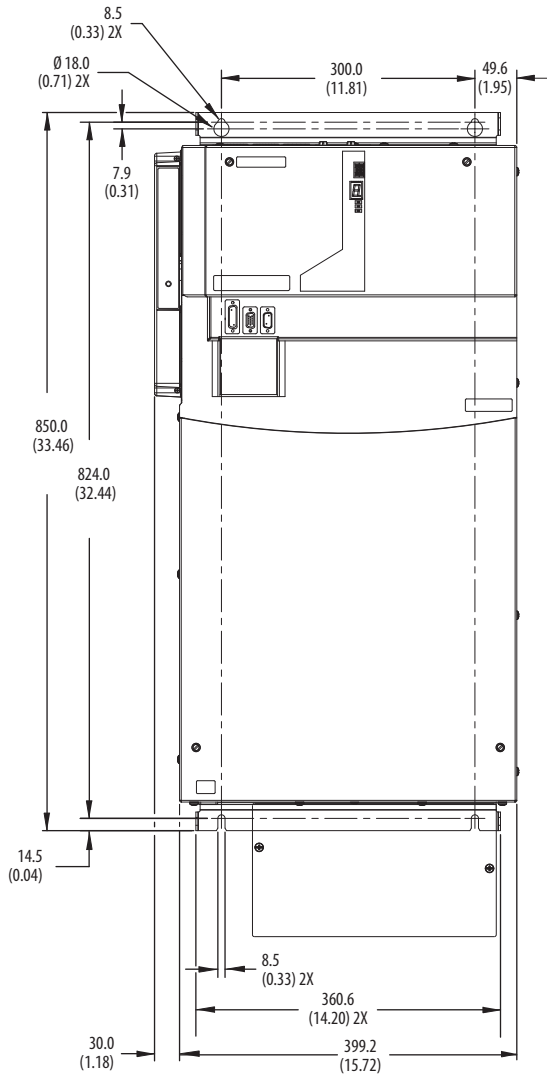

Dimensions are in mm (in.)

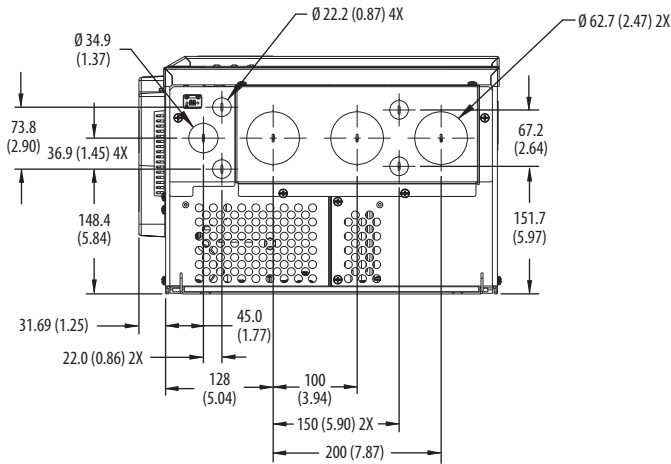
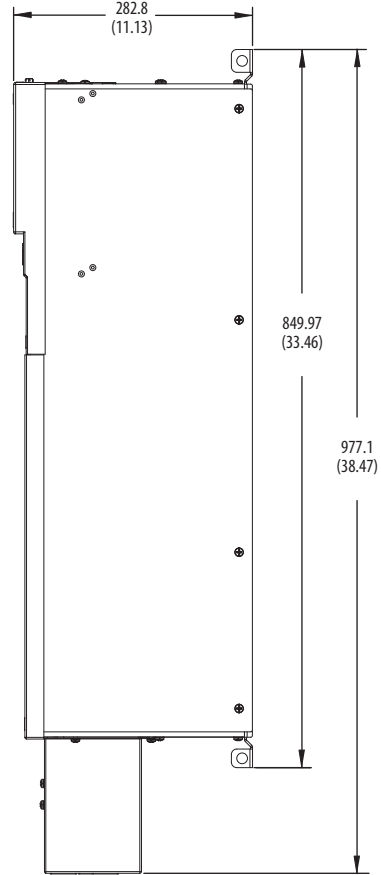

Environmental Specifications - Kinetix 7000 High Power Servo Drives

Attribute	Operational Range	Storage Range (nonoperating)
Temperature, ambient	0...50 °C (32...122 °F)	-40...+70 °C (-40...+158 °F)
Relative humidity	5...95% noncondensing	5...95% noncondensing
Altitude	1000 m (3281 ft) 3000 m (9843 ft) with derating	3000 m (9843 ft) during transport
Vibration	5...55 Hz @ 0.35 mm (0.014 in.) double amplitude, continuous displacement; 55...500 Hz @ 2.0 g peak constant acceleration (10 sweeps in each of 3 mutually perpendicular directions)	
Shock	15 g, 11 ms half-sine pulse (3 pulses in each direction of 3 mutually perpendicular directions)	

Certifications - Kinetix 7000 High Power Servo Drives

Agency Certification ⁽¹⁾	Standards
c-UL-us ⁽²⁾	UL Listed to U.S. and Canadian safety standards (UL 508C File E59272). Solid-state motor overload protection provides dynamic fold-back of motor current when 110% of the motor rating is reached with a peak current limit based on the peak rating of the motor as investigated by UL to comply with UL 508C (UL File E59272).
CE	European Union 2004/108/EC EMC Directive compliant with IEC 61800-3:2004 + A1:2012: Adjustable Speed Electrical Power Drive Systems - Part 3; EMC Product Standard including specific test methods. European Union 2006/95/EC Low Voltage Directive compliant with IEC 50178:1997 - Electronic Equipment for use in Power Installations.
Functional Safety	TÜV certified for functional safety: up to Performance Level (PL) e, Category 3 according to ISO 13849; up to SIL CL3 according to IEC 61508, IEC 61800-5-2, and IEC 62061 when used as described in the Kinetix Safe Torque Off Feature Safety Reference Manual, publication GMC-RM002 .
C-Tick	Australian Radiocommunications Act, compliant with: <ul style="list-style-type: none"> • Radiocommunications Act: 1992 • Radiocommunications (Electromagnetic Compatibility) Standard: 1998 • Radiocommunications (Compliance Labelling - Incidental Emissions) Notice: 1998 • AS/NZS CISPR 11: 2002 (Group 2, Class A)
KC	Korean Registration of Broadcasting and Communications Equipment, compliant with: <ul style="list-style-type: none"> • Article 58-2 of Radio Waves Act, Clause 3 • Registration number: KCC-REM-RAA-2099

(1) When product is marked, refer to publication [2099-CT003](#) for the Kinetix 7000 servo drives EU Declaration of Conformity certificate.

(2) UL has not evaluated the safe-off option in these products.

Accessories - Kinetix 7000 High Power Servo Drives

Cat. No.	Description
2099-K7KCB-1	Control board assembly kit. Replacement control board for 2099-BMxx-S drives.
2099-K7KCP-1	DC-DC converter cassette kit. Replacement DC-DC converter for 2099-BMxx-S drives.